

PROFESSIONAL VACUUM CLEANER

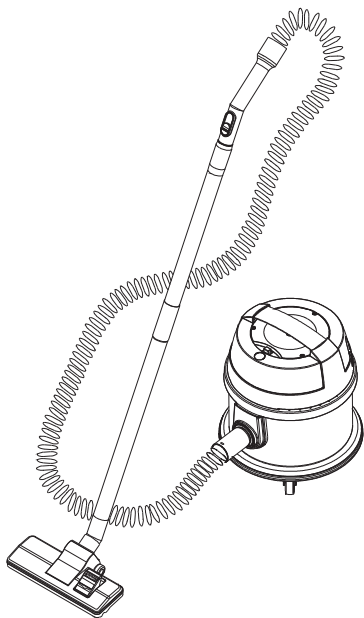

INSTRUCTION MANUAL



BUTLER
VACUUM CLEANER
1200 Watt

Made in Europe

Vacuum cleaner characteristics

Congratulations for choosing the BUTLER vacuum cleaner.

The vacuum cleaner was created to keep flats, offices, hotels, stores and all big surface areas clean.

Read these instructions carefully before using the vacuum cleaner.

Technical parameters of vacuum cleaner type BUTLER

Power - 1200 W

Supply current 240 V, 50 Hz

Cord - 10 m

Dust bag capacity 10 l

Mains safety (fuse) 16 A 

Protection class 

No RT interference level (EMC Compliant)

Full SAA approval for Australia and New Zealand

Elements of the vacuum cleaner

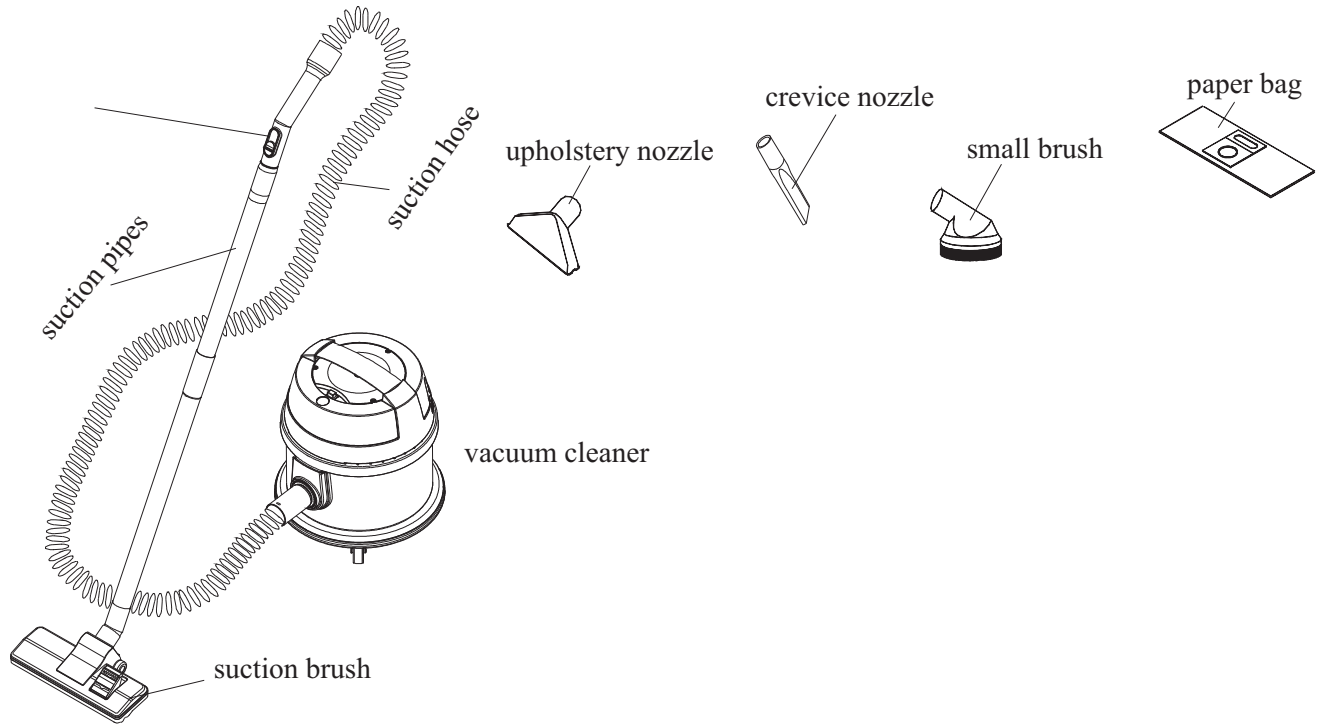

Using the vacuum cleaner

Prior to the first use you should:

- ◆ Check that the dust bag is correctly fitted onto the respective seat
- ◆ Insert the end of the hose into the cleaner, and twist to lock it in place.
- ◆ Insert the handle into the upper end of the suction pipe
- ◆ Insert the brush nozzle into the lower end of the suction pipe
- ◆ Unwind the power-supply cord and pay attention to its condition. If the cord insulation is damaged, don't use the cleaner and have it taken to a service agent for repair
- ◆ Plug the cord in the mains socket. Make sure the power supply is 240V
- ◆ To start, simply switch your vacuum cleaner ON by pressing down on the (ON/OFF) press button

After work one should:

- ◆ Switch the unit off and remove the plug from the wall socket
- ◆ Do not remove the plug by pulling on the cord, rather hold the plug and then remove it.
- ◆ Wrap the cord round the unit for safe storage.

The most important units of the vacuum cleaner

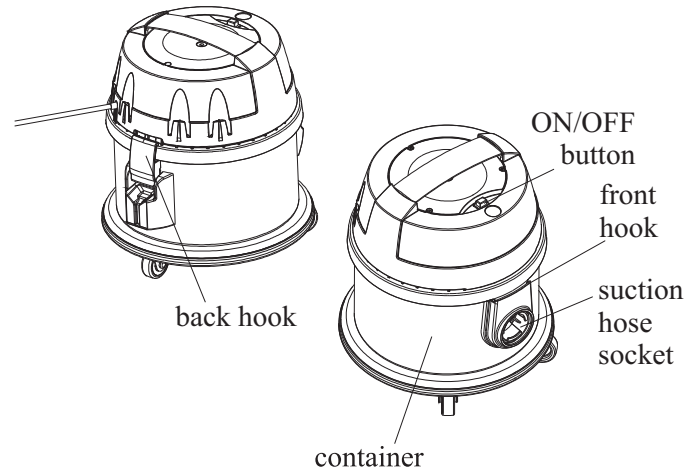

About the vacuum cleaner

- ◆ The BUTLER vacuum cleaner is compact, yet despite that it has an impressive 10-litre dust bag.
- ◆ It is engineered to be very quiet during operation. (Only 62dB)
- ◆ The long life motor is located in the upper part of the cleaner in the cover.
- ◆ The vacuum cleaner container is made of metal mounted on solid rubber wheels.
- ◆ Attachments are also provided to aid cleaning

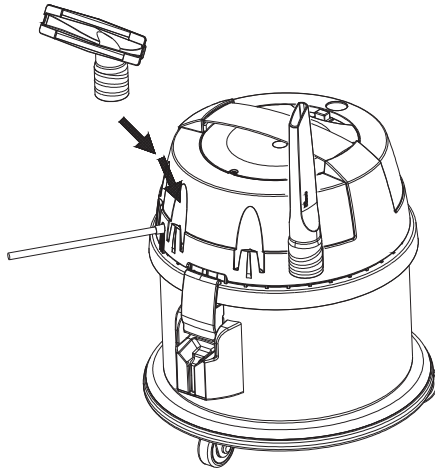

- ◆ The inlet filter is in the lower part of the cover. It should be cleaned from time to time. If it is damaged it must be replaced with a new one.

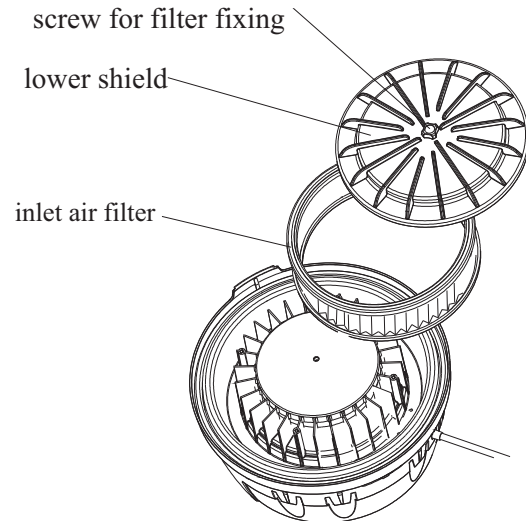

If the suction strength is reduced and cleaning of the filter does not help, the filter will have to be replaced with a new one!

Using the vacuum cleaner - foam filter replacement

- ◆ The foam outlet filter is under the upper lid of the vacuum cleaner.
- ◆ Unscrew the three screws and take off the cover to gain access to this filter.
- ◆ The filters used in the vacuum cleaner have a very large surface area for filtering. That is why they should be cleaned only if the suction strength is reduced.
- ◆ The foam filter can be washed in water, but it has to be dry before putting it back.

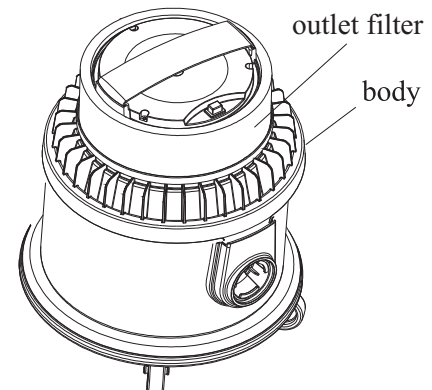
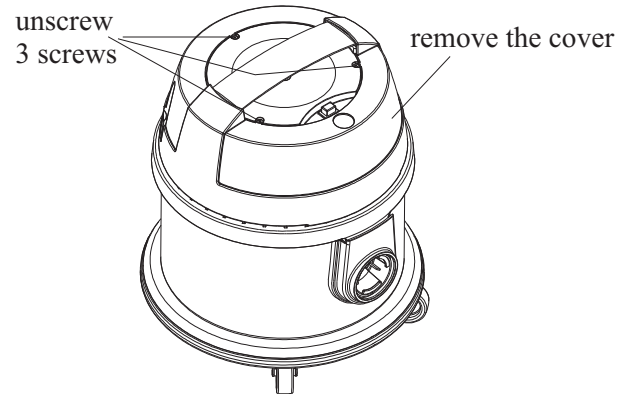

Using the vacuum cleaner - replacing the dust bag

- ◆ Switch the vacuum cleaner off
- ◆ Remove the hose from the vacuum cleaner
Release the back hook and detach the upper cover
- ◆ Remove the full dust bag by grasping the cardboard and remove the bag
- ◆ Insert a new dust bag by sliding the reinforcing part of the bag between the ribs at the bottom of the dust cassette.
- ◆ Make sure the dust bag is correctly fitted before re-attaching the suction hose to the cleaner
- ◆ Make sure you replace the top, upper cover of the vacuum cleaner before re-connecting the suction hose to container

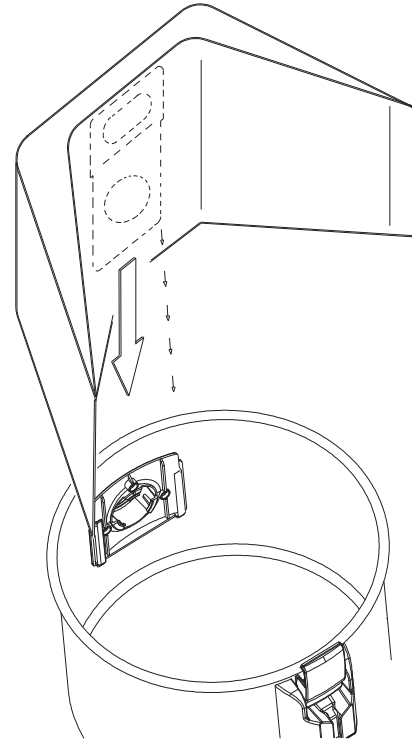

Application of equipment and their assembly

The suction hose is a basic element of the vacuum cleaners' equipment. Its flexibility allows the user to manoeuvre the equipment very easily. The suction hose handle is connected to the hose in a way that enables you to twist the suction hose during operation, preventing the hose from “bunching” up. There is a manual suction regulator on the suction hose handle, which regulates the suction power.

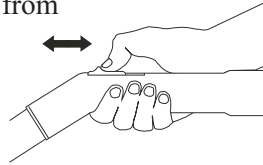

The suction pipes connect the nozzles and brushes to the suction hose handle which increases the vacuum cleaners' working range. Simply connect the 2 pipes together.

Upholstery nozzle is for cleaning surfaces such as upholstered furniture, window curtains, mattresses, cushions, etc.

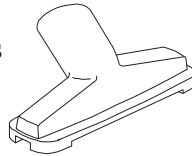

Small brush nozzle is intended for vacuuming uneven surfaces such as picture frames or books.



Crevice nozzle, the slim crevice nozzle enables cleaning areas which are difficult to access such as gaps, corners, recesses, etc



Suction brush. This accessory is versatile, enabling use on carpeted and hard floor areas. Switching from brush to nozzle is done by simply pressing on the button on the floor tool. With the bristles retracted, the floor tool is ready for use on carpeted surfaces. When pressing the button on the floor tool extends the bristles, you are ready to clean hard floor surfaces.

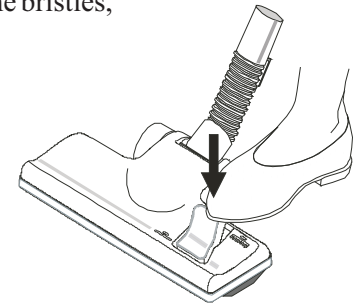

Caring for your Vacuum Cleaner

Never use the vacuum cleaner for:

- ◆ Vacuuming ash, cigarettes or matches. Never vacuum up any hot items whatsoever.
- ◆ Vacuuming glass, clips, staples or any other sharp objects.
- ◆ Vacuuming wet surfaces or surfaces with spills of water or other liquids. **This unit is strictly for dry dirt pick-up only.**
- ◆ Vacuuming gypsum, cement, stone powders, plaster dust, concrete dust, powders, etc.

How to take care of your vacuum cleaner

- ◆ Replace a full dust bag with a new one.
- ◆ Do not let the dust bag overflow.
- ◆ Check the filters regularly. Do not let them become too clogged as this will degrade suction performance.
- ◆ Clean only the outside of the vacuum cleaner.

- ◆ When cleaning the vacuum cleaner, do not use coarse cleaning agents which could scratch the housing.
- ◆ It is best to use a wet, soft piece of cloth moisturized with a mild cleaning agent to clean the vacuum cleaner.
- ◆ Make sure the vacuum cleaner is completely dry before reusing..

NEVER use the vacuum cleaner if the dust bag is ripped or the filters are damaged. This will damage the motor and void your warranty.

Important Safety Instructions

- ◆ This vacuum cleaner is not designed for persons (including children) with reduced physical, sensory or mental capabilities, or lack of experience and knowledge, unless they have been given supervision or instruction concerning use of the appliance by a person responsible for their safety.
- ◆ Children should be supervised to ensure that they do not play with the appliance. Children must not use this appliance. Never vacuum up any liquids whatsoever.
- ◆ One must not use this appliance if there are any noticeable abnormalities or irregularities. Make sure the insulation on the power cord is in good condition before plugging in the unit.
- ◆ If the supply cord is damaged, it must be replaced by the manufacturer, its service agent or similarly qualified persons in order to avoid a hazard.

The plug of the cord should be pulled out from a socket before cleaning the vacuum cleaner.

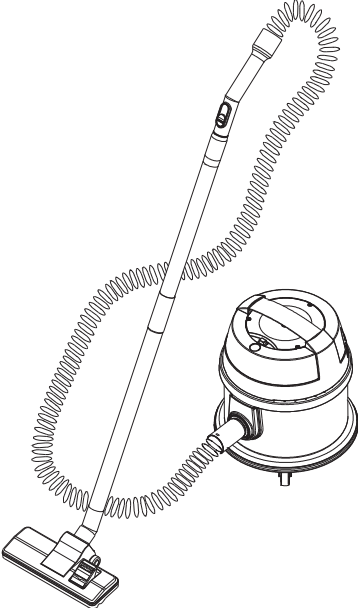



ABN: 51 121 002 104
59 Radford Road, Reservoir VICTORIA 3073
Phone: (03) 9460 5655 Fax: (03) 9460 5666
Email: sales@cleanstar.com.au Web: www.cleanstar.com.au

CONDITIONS OF WARRANTY

This document outlines the terms and conditions of warranty for your Cleanstar product. This is an important document that should be kept with your proof of purchase documents in a safe place for future reference should you require service for your product.

Thank you for purchasing your new Cleanstar product. We are confident this product will give you trouble-free use and excellent service, provided the operator uses and maintains the product in accordance with the Instruction Manual. Please read the Instruction Manual carefully before using the product for correct operation and maintenance procedures, and store it in a safe place for future reference.

1. This is a parts and labour warranty against faulty or defective parts, materials or workmanship in manufacturing, when the product is used and operated in accordance with the Instruction Manual.
2. This product carries a 12 month (1 year) warranty period that commences from the original date of purchase by the first user/purchaser, and is not transferable.
3. The warranty only covers use of the product to remove dry dirt and dust from flooring and other surfaces.
4. This warranty only applies to products purchased and used in Australia.
5. At all times during the warranty period, Cleanstar shall, at its sole discretion, determine whether repair, replacement or refund will apply if the product has a valid warranty claim applicable to it.
6. The repair or replacement of the product under this warranty does not extend the original period of warranty.
7. Please note that this warranty will be voided in the following cases (which are not exhaustive) and the warranty does not apply to the cost of replacing any parts of the product resulting from:
 - Accidental damage;
 - Normal wear and tear;
 - Neglect, misuse or physical abuse by the operator, including failure to properly maintain or service;
 - Any alterations, modifications or tampering with the product without the prior written consent of Cleanstar;
 - Incomplete or improper installation;
 - Incorrect, improper or inappropriate operation;
 - Insect or vermin infestation;
 - Power surges, electrical storm damage or incorrect power supply/voltage;
 - Excessive use or use for which this product has not been designed;
 - Vacuuming up water, liquids, toner, powders, glass, hazardous, flammable or corrosive materials, plaster dust, concrete dust and other similar building or construction materials;
 - Failure to comply with the operating instructions contained in the Manual supplied with the product;
 - If the product is rented;
 - If the product is used outside of Australia;
 - If the product was serviced or repaired by anyone other than Cleanstar, or one of Cleanstar's Authorised Service Agents (ASA). Cleanstar is unable to accept any responsibility under this warranty for any repair work not carried out by an ASA or from the use of non-genuine parts.
8. This warranty does not cover service calls, travelling time or consumable parts such as belts, dust bags, filters, hose or hose parts, rods and wands, floor tools and accessories, motor brushes and other like consumable items, unless defective in manufacture. In order to prolong the life of accessories and consumables, regular care and maintenance is recommended.
9. Please retain your original proof of purchase which will be required before you can make a claim under this warranty. If proof of purchase can not be provided at the time of a warranty claim or service, any work carried out on the cleaner is chargeable.
10. Any transportation and delivery costs involved in the repair of defective parts shall be borne by the claimant. In all instances, unless the product is transported by Cleanstar or a Cleanstar authorised representative, the product is transported at the owner's cost and risk while in transit to and from Cleanstar or its ASA.

Our goods come with guarantees that cannot be excluded under the Australian Consumer Law. You are entitled to a replacement or refund for a major failure and for compensation for any other reasonably foreseeable loss or damage. You are also entitled to have the goods repaired or replaced if the goods fail to be of acceptable quality and the failure does not amount to a major failure. The benefits conferred by this warranty are in addition to other rights and remedies under law in respect of the product to which this warranty relates.

TO INQUIRE ABOUT MAKING A CLAIM UNDER THIS WARRANTY, PLEASE FOLLOW THESE STEPS:

- a) carefully check the Instruction Manual and the terms of this warranty;
- b) have the name and model number of the appliance available;
- c) have the proof of purchase available (ie. invoice, receipt, etc) showing where the appliance was purchased from and date of purchase;
- d) call Cleanstar on **(03) 9460 5655** to speak to one of our customer service staff.